



EVERPURE® ENDURANCE® HIGH FLOW TWIN SYSTEM

DELIVERS PREMIUM QUALITY WATER FOR HIGH VOLUME COMBINATION APPLICATIONS

Endurance High Flow Twin: EV9437-30
Endurance Twin Cartridge Kit: EV9628-70*

* not shown



APPLICATIONS

Multiple equipment and combination applications
High volume installations

FEATURES • BENEFITS

Features Everpure SEN Cartridges with proprietary Fibredyne™ II media for superior contaminant reduction

Utilizes Everpure 2SR-BW Phosphate Cartridge for scale reduction

High capacity allows system to keep up with high water demands and allows longer periods between replacing filter cartridge

Outstanding dirt-holding capabilities

Unique pretreatment system features pleated membrane with a large surface area

Compact design has nearly the same footprint as the Everpure High Flow CSR Quad System

Sanitary cartridge replacement is simple, quick and clean, internal filter parts are never exposed to handling or contamination

NSF® Certified under NSF/ANSI Standards 42 and 53

INSTALLATION TIPS

Choose a mounting location capable of safely supporting the full weight of the system when in operation.

Use 3/4" water line.

Fountain equipment connections are made to the outlet part of the system before the Everpure 2SR-BW cartridge.

Coffee brewer and ice machine connections are made after the Everpure 2SR-BW scale inhibitor cartridge; a tee is required.

Install vertically with cartridges hanging down and allow 5" (12.7 cm) clearance below the cartridge for easy replacement.

Frame is designed to mount on 16" centers (wall studs).

OPERATION TIPS

Change filter cartridges on a regular 12-month preventative maintenance program.

Change cartridges when capacity is reached or when flow becomes too slow, but at least annually.

Always flush the filter cartridge at time of installation and cartridge change.

Flush cartridges by running water through flushing valve for five (5) minutes at full flow.

SIZING

Rated Service Flow: 7.5 gpm (28.4 Lpm)

Capacity: Up to 100,000 gallons (378,540 L)

EVERPURE® ENDURANCE® HIGH FLOW TWIN SYSTEM EV9437-30

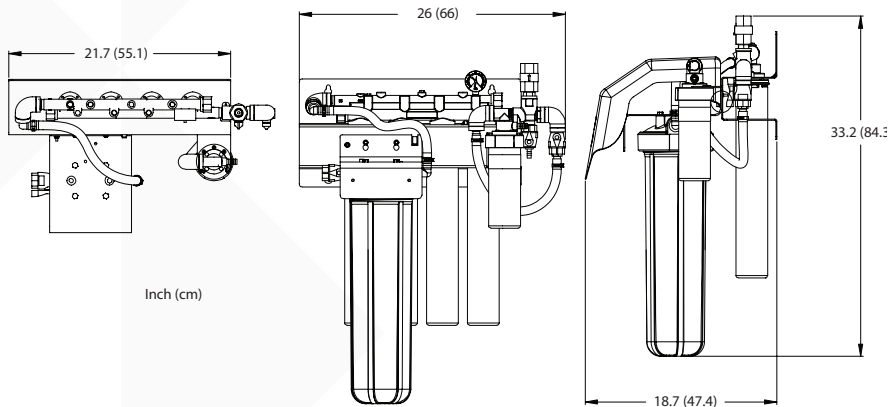

System Tested and Certified by NSF International against NSF/ANSI Standard 42 and 53 for the reduction of:

**Standard No. 42 —
Aesthetic Effects**

- Bacteriostatic Effects
- Chemical Reduction
- Taste and Odor
- Chlorine
- Mechanical Filtration
- Nominal Particulate Class I

**Standard No. 53 —
Health Effects**

- Mechanical Filtration
- Turbidity
- Cyst

SPECIFICATIONS

Overall Dimensions

33.2" H x 26" W x 18.7" D
(84.3 cm 66 cm x 47.4 cm)

Connections 3/4"

Capacity

100,000 gallons (378,541 L)

Rated Service Flow

7.5 gpm (28.4 Lpm)

Pressure Requirements

10 - 100 psi (0.7 - 6.9 bar), non-shock

Temperature

35 - 100°F (2 - 38°C)

Shipping Weight

43 lbs (19.5 kg)

Operating Weight

58.4 lbs. (26.5 kg)

Electrical Connection

None required

The contaminants or other substances removed or reduced by this drinking water system are not necessarily in your water. Do not use with water that is microbiologically unsafe or of unknown quality without adequate disinfection before or after the system. Systems certified for cyst reduction may be used with disinfected water that may contain filterable cysts.

WARRANTY

Everpure water treatment systems by Pentair® (excluding replaceable elements) are covered by a limited warranty against defects in material and workmanship for a period of five years after date of purchase. Everpure replaceable elements (filter cartridges and water treatment cartridges) are covered by a limited warranty against defects in material and workmanship for a period of one year after date of purchase. See printed warranty for details. Pentair will provide a copy of the warranty upon request.



FILTRATION & PROCESSING SOLUTIONS

EVERPURE-SHURFLO WORLD HEADQUARTERS, 1040 MUIRFIELD DRIVE, HANOVER PARK, IL 60133 USA • WWW.EVERPURE.COM
800.942.1153 MAIN (US ONLY) • 630.307.3000 MAIN • 630.307.3030 FAX • CSEVERPURE@PENTAIR.COM EMAIL

EVERPURE-SHURFLO AUSTRALIA / NEW ZEALAND, 1-21 MONASH DRIVE, DANDENONG SOUTH, VIC, 3175, AUSTRALIA
1300.576.190 TEL • AU.EVERPURE@PENTAIR.COM EMAIL

EVERPURE-SHURFLO CHINA, 21F CLOUD 9 PLAZA, NO 1118, SHANGHAI, 200052, CHINA
86.21.3211.4588 TEL • 86.21.3211.4580 FAX • CHINA.WATER@PENTAIR.COM EMAIL

EVERPURE-SHURFLO INDIA, GREEN BOULEVARD, B-9/A, 7TH FLOOR - TOWER B SECTOR 62, NOIDA - 201301
91.120.419.9444 TEL • 91.120.419.9400 FAX • INDIACUSTOMER@PENTAIR.COM EMAIL

EVERPURE-SHURFLO EUROPE, PENTAIR WATER BELGIUM BVBA, INDUSTRIEPARK WOLFSTEE, TOEKOMSTLAAN, 30 B-2200 HERENTALS, BELGIUM
+32.(0).14.283.500 TEL • +32.(0).14.283.505 FAX • SALES@EVERPURE-EUROPE.COM EMAIL

EVERPURE-SHURFLO JAPAN INC., HASHIMOTO MN BLDG. 7F, 3-25-1 HASHIMOTO, MIDORI-KU, SAGAMIHARA-SHI KANAGAWA 252-0143, JAPAN
81.(0)42.775.3011 TEL • 81.(0)42.775.3015 FAX • INFO@EVERPURE.CO.JP EMAIL

EVERPURE-SHURFLO SOUTHEAST ASIA, 18 BOON LAY WAY, #04-110/111, TRADEHUB 21, 609966, SINGAPORE
65.6795.2213 TEL • FAX: 65.6795.2219 FAX • CSEVERPURE@PENTAIR.COM EMAIL

All Pentair trademarks and logos are owned by Pentair, Inc. All other brand or product names are trademarks or registered marks of their respective owners. Because we are continuously improving our products and services, Pentair reserves the right to change specifications without prior notice. Pentair is an equal opportunity employer.