



# EVERPURE® ENDURANCE® SC HIGH FLOW TRIPLE 1.1 SYSTEM

ALL THE BENEFITS OF THE ENDURANCE PLATFORM PLUS ULTRAFILTER MEMBRANE-BASED PRETREATMENT



Endurance High Flow Triple: EV9437-41

## APPLICATIONS

Multiple equipment and combination applications  
High volume installations

Locations with high submicron particulate content in water source

## FEATURES • BENEFITS

High capacity allows system to keep up with high water demands and allows for 12-month estimated cartridge change-outs

High quality, ultrafiltration hollow fiber membranes are backward- and forward-flushed to remove built-up particle contaminants, providing long life to both the UF pretreatment membrane and the SEN Fine Filters

Backflushing occurs from the outside of the hollow membranes to the inside, which provides better dirt removal and reduced membrane breakage

Proprietary Fibredyne™ II media provides superior chlorine taste & odor reduction and micro-filters dirt and particles as small as 1/2-micron by mechanical means

Utilizes Everpure 2SR-BW Feeder System for scale reduction up to one (1) year

Filtration media effectively inhibits the growth of bacteria on the filter media that can decrease product life

Features extra head for future expandability as water requirements increase

System provides two water outlets for separate water qualities, ideal for carbonated, ice and hot beverages

Backflush Tank included for backflushing as well as water storage for peak water demand

NSF/ANSI Standard 53 certified to reduce cysts such as *Italic* and *Giardia* by mechanical means

## INSTALLATION TIPS

Choose a mounting location capable of safely supporting the full weight of the system when in operation.

Use 3/4" water line.

Fountain equipment connections are made to the outlet part of the system before the Everpure 2SR-BW Feeder System.

Coffee brewer and ice machine connections are made after the Everpure 2SR-BW Feeder System; a tee is required.

Install vertically with cartridges hanging down and allow 5" (12.7 cm) clearance below the cartridge for easy replacement.

Frame is designed to mount on 16" centers (wall studs).

## OPERATION TIPS

Hollow fiber cartridge life is approximately three (3) years.

Replace quick-change cartridges on a regular 12-month preventative maintenance program.

Always flush the filter cartridges at time of installation and cartridge change.

Flush cartridges by running water through flushing valve for five (5) minutes at full flow.

Electrical outlet is required to operate the backflushing of the system.

## SIZING

Rated Service Flow: 11.25 gpm (42.6 Lpm)

Capacity: Up to 150,000 gallons (567,812 L) or one (1) year.

# EVERPURE® ENDURANCE® SC HIGH FLOW TRIPLE 1.1 SYSTEM EV9437-41

## SPECIFICATIONS

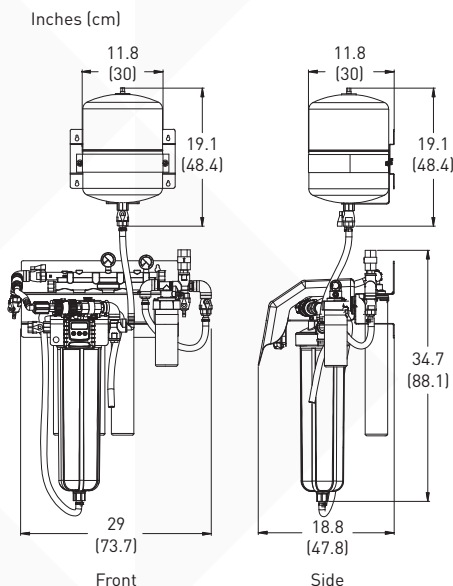

### Overall System Dimensions

34.7" H x 29" W x 18.8" D  
(88.1 cm x 73.7 cm x 47.8 cm)

### Tank Dimensions

19.1" H x 11.8" W x 11.8" D  
(48.4 cm x 30 cm x 30 cm)

### Connections

Inlet: 3/4" (19 mm)  
Outlet: 3/4" FPT (19 mm)  
Backwash: 3/4" (19 mm) I.D. Tube  
2SR-BW Cartridge: 1/2" (13.6 mm) Barb  
Flush Ports: 3/8" (9.5 mm) Barb

### Capacity

150,000 gallons (567,812 L) or one year

### Rated Service Flow

11.25 gpm (42.6 Lpm)

### Pressure Requirements

50 - 100 psi (3.5 - 6.9 bar), non-shock

### Temperature

35 - 100°F (2 - 38°C)

### Shipping Weight

67 lbs (30.4 kgs)

### Operating Weight

111.5 lbs (50.6 kgs)

### Electrical Connection

100 - 240 VAC / 50 - 60 Hz  
1.5 Amp (international plugs included)

### Replacement Parts

Endurance SC Triple 1.1 Cartridge Kit:  
EV9628-81

Endurance SC UF Membrane  
Pretreatment Filter: EV9628-81

The contaminants or other substances removed or reduced by this drinking water system are not necessarily in your water. Do not use with water that is microbiologically unsafe or of unknown quality without adequate disinfection before or after the system. Systems certified for cyst reduction may be used with disinfected water that may contain filterable cysts.

## WARRANTY

Everpure water treatment systems by Pentair® (excluding replaceable elements) are covered by a limited warranty against defects in material and workmanship for a period of five years after date of purchase. Everpure replaceable elements (filter cartridges and water treatment cartridges) are covered by a limited warranty against defects in material and workmanship for a period of one year after date of purchase. See printed warranty for details. Pentair will provide a copy of the warranty upon request.



## FILTRATION & PROCESSING SOLUTIONS

EVERPURE-SHURFLO WORLD HEADQUARTERS, 1040 MUIRFIELD DRIVE, HANOVER PARK, IL 60133 USA • WWW.EVERPURE.COM  
800.942.1153 (US ONLY) • 630.307.3000 MAIN • 630.307.3030 FAX • CSEVERPURE@PENTAIR.COM EMAIL

EVERPURE-SHURFLO AUSTRALIA, 1-21 MONASH DRIVE, DANDENONG SOUTH, VIC 3175, AUSTRALIA  
011.1300 576 190 TEL • 011.61.39.562.7237 FAX • AU.EVERPURE@PENTAIR.COM EMAIL

EVERPURE-SHURFLO CHINA, 21F CLOUD 9 PLAZA, NO 1118, SHANGHAI, 200052, CHINA  
86.21.3211.4588 TEL • 86.21.3211.4580 FAX • CHINA.WATER@PENTAIR.COM EMAIL

EVERPURE-SHURFLO INDIA, GREEN BOULEVARD, B-9/A, 7TH FLOOR - TOWER B SECTOR 62, NOIDA - 201301  
91.120.419.9444 TEL • 91.120.419.9400 FAX • INDIACUSTOMER@PENTAIR.COM EMAIL

EVERPURE-SHURFLO EUROPE, PENTAIR WATER BELGIUM BVBA, INDUSTRIEPARK WOLFSTEE, TOEKOMSTLAAN, 30 B-2200 HERENTALS, BELGIUM  
+32.(0).14.283.500 TEL • +32.(0).14.283.505 FAX • SALES@EVERPURE-EUROPE.COM EMAIL

EVERPURE-SHURFLO JAPAN INC., HASHIMOTO MN BLDG. 7F, 3-25-1 HASHIMOTO, MIDORI-KU, SAGAMIHARA-SHI KANAGAWA 252-0143, JAPAN  
81.(0)42.775.3011 TEL • 81.(0)42.775.3015 FAX • INFO@EVERPURE.CO.JP EMAIL

EVERPURE-SHURFLO SOUTHEAST ASIA, SOUTHEAST ASIA, 390 HAVELOCK ROAD, #04-01 KING'S CENTRE, SINGAPORE 169662  
65.6768.5800 TEL • 65.6737.5149 FAX • CSEVERPURE@PENTAIR.COM EMAIL

All Pentair trademarks and logos are owned by Pentair, Inc. or its affiliates. All other registered and unregistered trademarks and logos are the property of their respective owners. Because we are continuously improving our products and services, Pentair reserves the right to change specifications without prior notice. Pentair is an equal opportunity employer.

System Tested and Certified by NSF International against NSF/ANSI Standard 42 and 53 for the reduction of:

**Standard No. 42 — Aesthetic Effects**

- Bacteriostatic Effects
- Chemical Reduction
- Taste and Odor
- Chlorine
- Mechanical Filtration
- Nominal Particulate Class I

**Standard No. 53 — Health Effects**

- Mechanical Filtration
- Turbidity
- Cyst



EPA Est. No. 002623-IL-002