



VZN-441V



VZN-441V-T5



Replacement Element Tested and Certified by NSF International against NSF/ANSI Standard 42 and 53 for the reduction of:

Standard No. 42: Aesthetic Effects  
Nominal Particulate Reduction Class I  
Standard no. 53: Health Effects  
Cyst Reduction Turbidity Reduction.



## VZN Vertical Series

**VIZION** offers systems that deliver high-quality ingredient water to McDonald's entire beverage portfolio, ensuring superior beverages while minimizing the restaurant's operating costs.

The VZN systems use self-cleaning ultra filtration ahead of a low-cost carbon cartridge to separate mechanical filtration from taste and odor reduction. This self-cleaning and separation assures the full stated life expectancy of the carbon cartridge and provides it with mechanically pure water, which eliminates premature clogging. In the VZN-441V-T5, these technologies are then followed by template-assisted crystallization to protect your equipment against lime scale buildup.

### FEATURES AND BENEFITS:

- Mounts on the Multiplex or wall.
- Separation of mechanical filtration from taste and odor reduction assures long time between cartridge changes.
- Assures only one low-cost carbon cartridge change every six months.
- Self-cleaning particle reduction assures low maintenance costs.
- .015 micron ultra filter removes particles 33 times finer than the next best system, assuring consistent high quality water.
- TAC cartridge reduces lime scale by 96–98% without using chemicals or wasting water.
- Maintains good water minerals that provide benefits to customers' health while also creating high-quality drinks.
- Small footprint ideal for small back rooms.

## VZN Vertical Series

### Dimensions

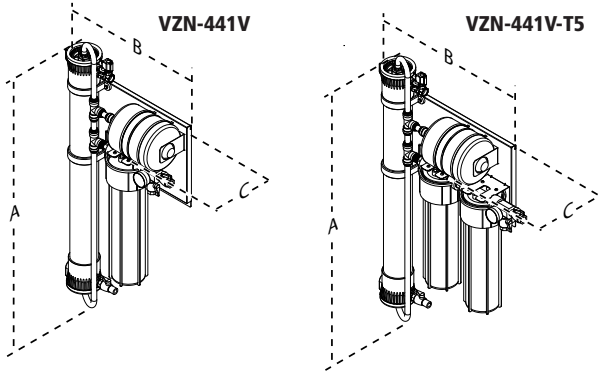

Model & Mfg. No.	Height (A)	Width (B)	Depth (C)	Operating Weight
VZN-441V 9700741	49 5/16" (125 cm)	24" (61 cm)	10 1/8" (26 cm)	83 lbs. (38 kg)
VZN-441V-T5 9700751	49 5/16" (125 cm)	32 3/4" (83 cm)	10 1/8" (26 cm)	98 lbs. (44 kg)

### Plumbing Connections

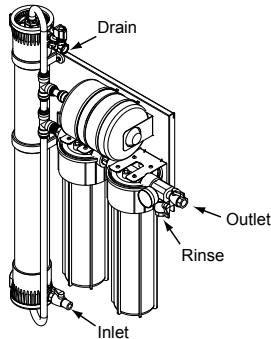

Inlet	3/4" MNPT
Outlet	3/4" MNPT
Drain	3/4" FNPT
Rinse	3/4" GHT

### Electrical Ratings and Plug Configurations

Model & Mfg. No.	Volts	Watts	Amps	Hertz
VZN-441V 9700741	100-240	10	.08	50/60
VZN-441V-T5 9700751	100-240	10	.08	50/60

**NOTE: Includes plug adaptors for US, Europe, Australia, and UK.**

### Capacities

Model & Mfg. No.	Capacity Per Minute	UF Length	No. of Carbon Elements	No. of TAC Cartridges
VZN-441V 9700741	13 gal. (49 liters)	40" (102 cm)	1	0
VZN-441V-T5 9700751	13 gal. (49 liters)	40" (102 cm)	1	1

### Specifications (Ultra Filter)

Maximum Operating Pressure	100 psig (690 kPa)
Maximum Operating Temperature	104°F (40°C)
Nominal Pore Size	.015 microns
pH Range	3-10
MWCO	100-150 kD

### Expected Life Span

Carbon Element	6 months
Ultra Filter	5 years
TAC Cartridge	5 years



A.J. Antunes & Co.  
Headquarters/Manufacturing  
180 Kehoe Boulevard  
Carol Stream, Illinois 60188 USA  
Phone (630) 784-1000  
Toll Free (800) 253-2991  
Fax: (630) 784-1650

Antunes Equipment  
Manufacturing (Suzhou) Ltd.,  
9 Hou Ju Road, Building #24,  
S&T Park, SND  
Suzhou, Jiangsu, China 215011  
Phone: 86-512-6841-3637  
Fax: 86-512-6841-3907

[www.ajantunes.com](http://www.ajantunes.com)