



BEVERAGE-AIR

3779 Champion Blvd., Winston-Salem, NC 27105
1-888-845-9800 Fax# 1-336-245-6453
<http://www.Beverage-Air.com>

Commercial Refrigeration Equipment General Specification

CABINET CONSTRUCTION

Heavy-duty construction includes stainless front (doors and grilles). Exterior sides are stainless steel. Exterior top, back and bottom are stainless steel. Cabinet includes interior thermometer and interior fluorescent light.

Two shelves per door section standard.

Foamed-in-place CFC and HCFC-free polyurethane insulation enhances the structural strength of the cabinet and helps increase energy efficiency.

RI18-HGS model features (1) "half-size glass door" and (1) "half-size solid door." RI18-HS-26 model features (2) "half-size doors". RID18 Pass-Thru models feature (1) "half-size glass door" and (1) "half-size solid door" per side. Doors attach to cabinet on cam-lift hinges. Hinges permit doors to stay open at 120° and gravity self-close. A plug-in type, vinyl magnetic gasket is attached to each door. Three-inch heavy-duty casters included, two with brakes standard.

REFRIGERATION

Balanced refrigeration system is located at bottom of cabinet. System uses R134a refrigerant, which is CFC and HCFC-free for compliance with environmental safety concerns.

SPECIAL FEATURES

- RI18-HGS model features (1) "half-size glass door" and (1) "half-size solid door."
- RI18-HS-26 model features (2) "half-size doors."
- RID18 Pass-Thru models feature (1) "half-size glass door" and (1) "half-size solid door" per side.
- 3" casters included, two with brakes standard.

Item No. _____
Quantity _____

BOTTOM MOUNTED REACH-IN & PASS-THRU REFRIGERATORS RI18 SERIES

MODELS:
RI18-HGS
RI18-HS-26
RID18-HGS



RI18-HGS

Available From:



*Note: Not all markings may apply to all model variations.

Model Specified _____	Store# _____
Location _____	Quantity _____



BEVERAGE-AIR

Bottom Mount, RI18 Series Refrigerators

Models: RI18-HGS, RID18-HGS

MODEL	RI18-HGS	RI18-HS-26	RID18-HGS
EXTERNAL DIMENSIONAL DATA			
Length Overall (inches)	27 1/4"	27 1/4"	27 1/4"
Length Overall (mm)	692	692	692
Depth Overall—(inches) less handle	27 1/2"	27 1/2"	29 1/2"
Depth Overall—(mm) less handle	699	699	749
Height Overall—(inches) less casters	69 1/4"	69 1/4"	69 1/4"
Height Overall—(mm) less casters	1759	1759	1759
Number of doors	2	2	4
INTERNAL DIMENSIONAL DATA			
NET Capacity (cubic ft.)	18	18	18
NET Capacity (Liters)	510	510	510
Internal Length Overall (inches)	24"	24"	24"
Internal Length Overall (mm)	610	610	610
Internal Depth Overall (inches)	24"	24"	24"
Internal Depth Overall (mm)	610	610	610
Internal Height Overall (inches)	46 1/2"	46 1/2"	46 1/2"
Internal Height Overall (mm)	1181	1181	1181
Number of shelves	4	4	4
ELECTRICAL DATA			
Full Load Amperes 115/60/1	5.9	5.9	5.9
REFRIGERATION DATA			
Horsepower	1/4	1/4	1/4
WEIGHT DATA			
Gross Weight (Crated lbs)	339	339	339
Gross Weight (Crated kg)	154	154	154

PLAN VIEWS

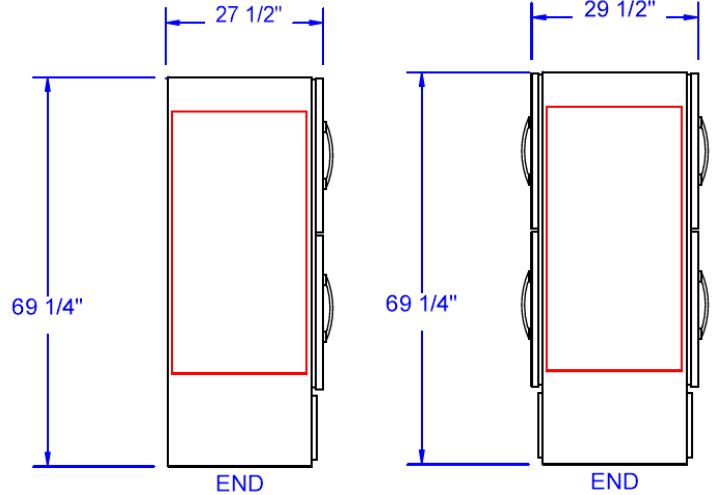

**RI18-HGS
RI18-HS-26**

RID18-HGS



*Note: Not all markings may apply to all model variations.

ELECTRICAL CONNECTION

Units pre-wired at factory and include 8' long cord and plug set.

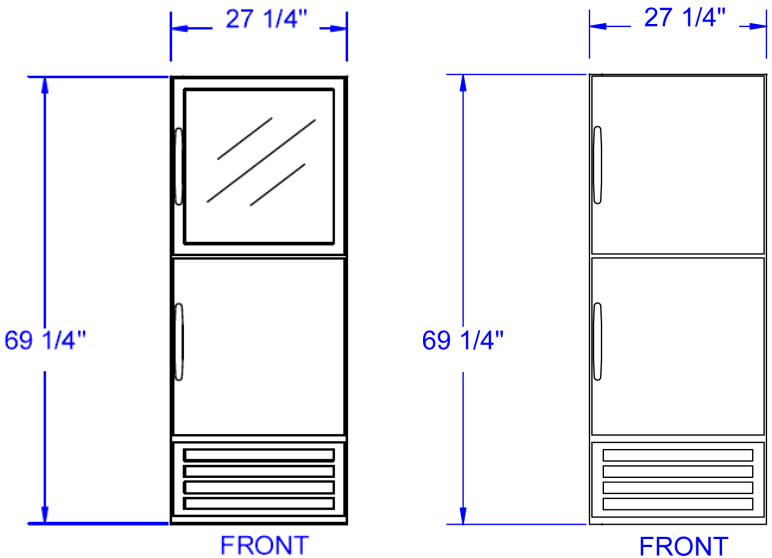

RI18-HGS/RID18-HGS

RI18-HS-26

BEVERAGE-AIR® CORPORATION

3779 Champion Blvd. • Winston-Salem, NC 27105 USA • (336) 245-6400 • Fax (336) 245-6453 • (888) 845-9800 • www.beverage-air.com

Specifications are subject to change without prior notice. 04/11