

# Indigo™ Series 1200 Ice Cube Machine

Model:  ID-1202A  IY-1204A  ID-1203W  IY-1205W



Indigo Series i-1200  
Ice Machine on B-570 Bin

Designed for operators who know that ice is critical to their business, the Indigo™ Series ice machine's preventative diagnostics continually monitor itself for reliable ice production. Improvements in cleanability and programmability make your ice machine easy to own and less expensive to operate.

- **Space-Saving Design** – Up to 1,205 lbs. (547 kgs.) daily ice production and only 30" (76.20 cm) wide.
- **Intelligent Diagnostics** – provide 24 hour preventative maintenance and diagnostic feedback for trouble free operation.
- **Acoustical Ice Sensing Probe** – for reliable operation in challenging water conditions.
- **EasyRead Display** – communicates operating status, cleaning reminders, and asset information through a blue illuminated display.
- **Programmable Ice Production** – by On/Off Time, Ice Volume or Bin Level (with accessory bin level control) further improves energy efficiency and savings.
- **Easy to Clean Foodzone** – Hinged front door swings out for easy access. Removable water-trough, distribution tube, curtain, and sensing probes for fast and efficient cleaning. Select components made with AlphaSan® antimicrobial.
- **DuraTech™ Exterior** – provides superior corrosion resistance. Stainless finish with innovative clear-coat resists fingerprints and dirt.
- Available **LuminIce™ Growth Inhibitor** controls the growth of bacteria and yeast within the foodzone.

## Ice Machine Electric

208-230/60/1 standard  
(208-230/60/3 and 230/50/1 also available.)

### Minimum circuit ampacity:

Air-cooled: 25 1ph      16 3ph  
Water-cooled: 25 1ph      16 3ph

### Maximum fuse size:

Air-cooled: 25 1ph      20 3ph  
Water-cooled: 25 1ph      20 3ph



## Specifications

### BTU Per Hour:

20,700 (average) 24,500 (peak)

### Refrigerant:

R-404A CFC-free

### Operating Limits:

- Ambient Temperature Range: 35° to 110°F (1.7° to 43.3°C)  
Water Temperature Range: 35° to 90°F (1.7° to 32.2°C)
- Water Pressure Ice Maker Water In:  
Min. 20 psi (137.9 kPa)  
Max. 80 psi (551.1 kPa)

## Ice Shape



**Half Dice**  
3/8" x 1 1/8" x 7/8"  
(.95 x 2.86 x 2.22 cm)



**Dice**  
7/8" x 7/8" x 7/8"  
(2.22 x 2.22 x 2.22 cm)





# Indigo™ Series 1200 Ice Cube Machine

## i-1200 on B-570 Storage Bin

- (A) Electrical Entrance (2) Options
- (B) 3/8" (0.95 cm) F.P.T. Water Condenser Inlet (water-cooled units)
- (C) 1/2" (1.27 cm) F.P.T. Water Condenser Outlet (water-cooled units)
- (D) 1/2" (1.27 cm) Auxillary Base Drain Socket
- (E) 3/8" (0.95 cm) F.P.T. Ice Making Water Inlet
- (F) 1/2" (1.27 cm) F.P.T. Ice Making Water Drain
- (G) 3/4" (1.91 cm) Bin Drain

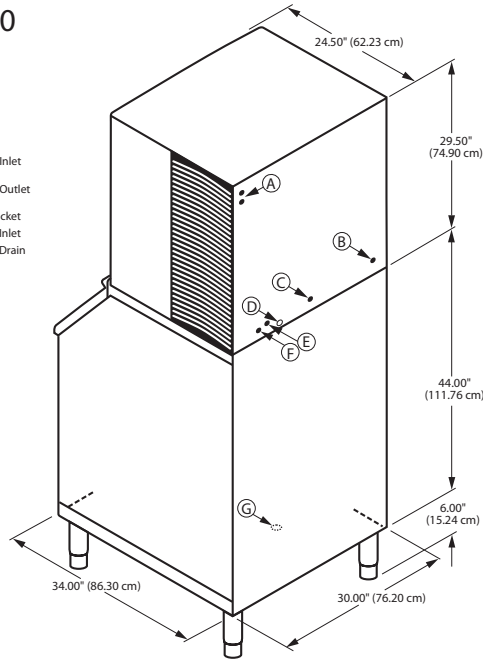

### Installation Note

**Air Cooled clearance:**

- Top: 8" (20.3 cm)
- Sides: 12" (30.5 cm)
- Back: 5" (12.7 cm)

**Water Cooled clearance:**

- Top/Sides: 8" (20.3 cm)
- Back: 5" (12.7 cm)

## Space-Saving Designs



	<b>i-1200 B-570</b>	<b>i-1200 B-970*</b>
Height	79.50" 201.93 cm	79.50" 201.93 cm
Width	30.00" 76.20 cm	48.00" 121.92 cm
Depth	34.00" 86.30 cm	34.00" 86.30 cm
Bin Storage	430 lbs. 195 kgs.	710 lbs. 322.2 kgs.

Height includes adjustable bin legs 6.00" to 8.00" (15.24 to 20.32 cm) set at 6.00" (15.24 cm).

\*K-00370 bin adapter required.

## Specifications

	Model	Ice Shape	Ice Production 24 Hours		Power Usage kWh/100 lbs. @90°Air/70°F		Water Usage/ 100 lbs. 45.4 kgs. of Ice	ENERGY STAR*
			70°Air/ 50°F Water	90°Air/ 70°F Water	1 Ph	3 Ph	Potable Water	
<b>AIR-COOLED</b>	ID-1202A	dice	1,100 lbs.	870 lbs.	5.32	5.32	20.7 gal.	★
			499 kgs.	395 kgs.			78.4 L.	
<b>AIR-COOLED</b>	IY-1204A	half-dice	1,205 lbs.	930 lbs.	5.26	5.26	20.7 gal.	★
			547 kgs.	422 kgs.			78.4 L.	
<b>WATER-COOLED</b>	ID-1203W	dice	1,165 lbs.	900 lbs.	4.58	4.58	20.7 gal.	NA
			528 kgs.	408 kgs.			78.4 L.	
	IY-1205W	half-dice	1,170 lbs.	1,010 lbs.	4.40	4.40	20.7 gal.	NA
			531 kgs.	458 kgs.			78.4 L.	

\* Water-cooled Condenser Water Usage / 100 lbs. /45.4 kgs. Of Ice: 169 gal. / 640 L.

\* Water-cooled models are excluded from ENERGY STAR qualification.

Order ice storage bin separately. To order 3 phase add "3" suffix to model # (ID-1202A3).

## Accessories

**LuminIce™ Growth Inhibitor**  
reduces yeast and bacteria growth for a cleaner ice machine.



**Bin Level Control**  
Allows ice bin level to be automatically set. Built-in LED light illuminates bin.



**Arctic Pure® Water Filters**  
Reduces sediment and chlorine odors for better tasting ice.



**AuCS®**  
schedules and performs routine ice machine cleaning automatically.

