

An Ice Machine Designed  
Specifically for Beverage Dispensers

## Ice/Beverage Series 800C Remote

Ice Cube Machine with CVD Technology®  
Patented



Ice/Beverage Series IB-800C ice machine - 115V  
SerVend MD-175 beverage dispenser

An "NSF Listed" Ice/Beverage Dispenser Combination



CVD Condensing Unit - 208-230V

- Narrow, small footprint enhances cleanability; allows for improved sanitation procedures for the ice storage area and beverage valves. Will not obstruct sight lines. Also allows for convenient manual loading of ice in dispenser to satisfy peak ice usage
- Can be installed or retrofitted to virtually any commercial beverage dispenser
- Only 14" (35.56 cm) deep, 22" (55.88 cm) wide, and 26.5" (67.31 cm) high
- Up to 760\* lbs. (345 kgs.) daily ice production  
\*Production rating outside the scope of ARI Standard 810.
- Quiet operation eliminates most noise from the refrigeration system. Promotes relaxing atmosphere
- Stainless steel exterior with fit and finish of an appliance enhances any self-serve environment
- Patented built-in cleaning and sanitizing technology
- Ice machine is lighter in weight. 115 volt simplifies installation and maintenance
- CVD technology improves reliability and extends life of the compressor
- Ice/Beverage ice machines do not have stack-on capability
- Ice/Beverage QuietQube® series remote system consists of an ice machine head section, a CVD remote condensing unit, interconnecting refrigerant lines and a dispenser adapter. All ordered separately. Ice/Beverage QuietQube ice cube machine with CVD condensing unit is designed as a Manitowoc system and not for use with any other ice machine or remote condenser brand
- Warranty
  - 5-year parts and 5-year labor coverage on ice machine evaporator
  - 5-year parts and 3-year labor coverage on ice machine compressor
  - 3 year parts-and-labor coverage on all other ice machine components



THE RIGHT CLIMATE FOR LEADERSHIP

**Manitowoc®**

ICE CUBE & FLAKE MACHINES • ICE STORAGE BINS • ICE DISPENSERS

# Manitowoc Ice/Beverage IB-800C Remote Series

## REMOTE AIR-COOLED ICE MACHINE

Model	Cube size	Ice production 24 hours		Power* kWh/100 lbs.	
		lbs.	kgs.	6.6 1ph	6.8 3ph
IB-0822DC	dice	680	309	6.6 1ph	6.8 3ph
IB-0824YC	half-dice	680	309	6.6 1ph	6.8 3ph

Water usage/100 lbs./45.4 kgs. of Ice • Potable Water: 26.4 gallons, 100 liters

Ice machine for use with ice dispenser, CVD condensing unit and dispenser adapter. All ordered separately.  
\*kWh per 100 lbs. is total power of ice machine and condensing unit. Ice machine is 1 ph only.  
Condensing unit is 1 ph or 3 ph.

 **Certified in Accordance with ARI Automatic Commercial Ice-Cube Machines (Batch-Type) Certification Program, which is based on ARI Standard 810**

### Ice Machine Electric

**115/60/1 standard.**  
(208-230/60/1 and 230/50/1 also available, consult factory.)

**Total amps: 1.1**

**Max. fuse size: 15 amps**

HACR-type circuit breakers can be used in place of fuses.

### Specifications

**BTU Per Hour:**  
12,400 (average) 19,500 (peak)

**Compressor:**  
Nominal rating: 1.5 HP

**Operating Limits:**

- Ambient Temperature Range: 35° to 110°F (1.6° to 43.4°C)

- Water Temperature Range: 33° to 90°F (0.6° to 32.2°C)

- Water Pressure Ice Maker Water In: Min. 20 psi (137.9 kPa) Max. 80 psi (551.1 kPa)

**Refrigerant: R-404A**

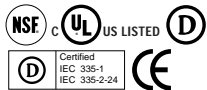

 **ISO 9001 Quality System Certified**

24-HOUR PRODUCTION †		lbs. kgs.	
REMOTE AIR-COOLED UNIT			
air temp	water temp		
°F	50°	70°	90°
°C	10°	21°	32°
-20° to 70°	760	690	640
-29° to 21°	345	314	291
90°	750	680	640
32°	341	309	291
100°	700	650	610
38°	318	295	277

†Production for Dice and Half Dice cubes.

### 2 Cube Sizes Available

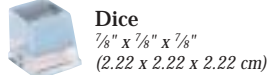
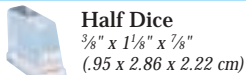

### AuCS® Accessory

 **AuCS® Automatic Cleaning System**

**Note:** IB models are designed for use with an Ice/Beverage dispenser. Adapter required. Ordered separately. For attachment to ice storage bin, contact factory.



## CVD 0875 REMOTE CONDENSING UNIT

### Installation Information and Dimensions:

Maximum Line Length—100' (30.5 m).\*

Maximum Vertical Rise\*—35' (10.7 m) above ice machine.

Maximum Vertical Drop—15' (4.5 m) below ice machine.

\*A rise over 20' (6 m) requires S-Trap Kit K-00172 - ordered separately.



### Condensing Unit Electric

**208-230/60/1 standard.** 208-230/60/3 and 230/50/1 also available. 50 Hz version of this model meets the international standard, IEC335-1, requirements for "tropical rating," the most severe duty rating an ice machine can obtain, (consult factory). HACR-type circuit breakers can be used in place of fuses.

**Note:** QuietQube ice machine is 115/60/1 and wired independent of CVD condensing unit.

**Min. circuit ampacity:** 11.7 1ph, 8.2 3ph

**Max. fuse size:** 20 amps 1ph, 15 amps 3ph

HACR-type circuit breakers can be used in place of fuses.

**Operating Limits:**

- Ambient Temperature Range: -20° to 130°F (-29° to 54°C)

### Standard Interconnecting Tubing

Model	Line Length		Weight	
	ft.	m.	lbs.	kgs.
RC-21	20	6	10	5
RC-31	30	9	15	7
RC-51	50	15	25	12



### Typical Installation

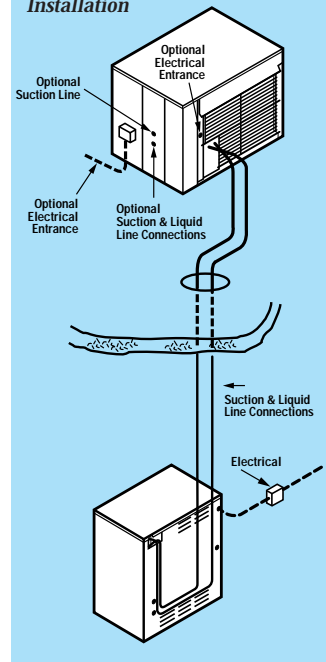

### CVD-0875 Condensing Unit

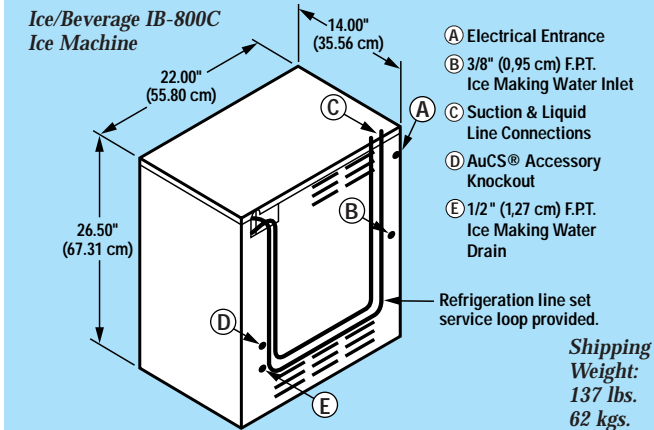
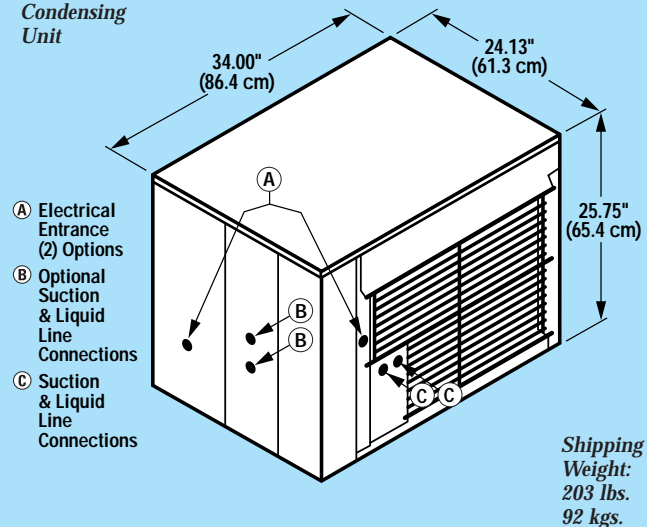

## THE RIGHT CLIMATE FOR LEADERSHIP

Consult your local Manitowoc Representative:

Manitowoc Ice, Inc.  
2110 South 26th Street, P.O. Box 1720 • Manitowoc, WI 54221-1720, USA  
Ph: 920-682-0161 • Fax: 920-683-7589  
[www.manitowocice.com](http://www.manitowocice.com)

A  Company

©2002 Manitowoc 9738C - 12/02

Continuing product improvement may necessitate change of specifications without notice.

