

# S-Series 422 Ice Cube Machine



SY-0424A Ice Machine  
on B-420 Bin

- SANITATION**  
We've made it simple to clean
- SAVINGS**  
The perfect balance of power and efficiency
- SOUND**  
Designed to run whisper-quiet
- SERVICEABILITY**  
Easy access means less downtime

- Up to 460 lbs. (209 kgs.) daily ice production
- Up to CEE Tier 2 energy and water efficiency rating
- Only 22" (55.88 cm) wide
- Removable water distribution tube with no tools
- Food zone designed with soft, round, cove corners
- Patented cleaning and sanitizing technology
- Select components made with AlphaSan® antimicrobial
- Hinged front door for easy access
- Warranty
  - 5-year parts and 5-year labor coverage on ice machine evaporator
  - 5-year parts and 3-year labor coverage on ice machine compressor
  - 3-year parts-and-labor coverage on all other ice machine, dispenser, and storage bin components

America's #1 Selling Ice Machine  
Ice Cube & Flake Machines • Ice Storage Bins • Ice Dispensers



# Manitowoc S-Series 422

Model	Ice Shape	Ice Production 24 Hours				Power KWh/100 lbs. @ 90°/70°F	CEE* Rating	ENERGY STAR*
		70° Air/50°F Water		90° Air/70°F Water				
		lbs.	kgs.	lbs.	kgs.			
SY-0424A	half-dice	460	209	355	161	6.5	Tier 2	★
SY-0425W	half-dice	435	197	370	168	5.1	Tier 2	
SD-0422A	dice	430	195	320	145	7.1	Tier 1	
SD-0423W	dice	430	195	370	168	5.4	Tier 1	

Water usage/100 lbs./45.4 kgs. of Ice

Potable Water: 18 gallons, 68 liters • Water-cooled Condenser: 153 gallons, 579 liters.

Order ice storage bin separately. "A" or "W" following model number indicates "Air" or "Water" condensing unit.

**Consortium for Energy Efficiency (CEE)** is a North American nonprofit organization that promotes energy-efficient products, technologies and services; also the principal entity for the development of ice maker efficiency standards.



Certified in Accordance with ARI Automatic Commercial Ice-Cube Machines (Batch-Type) Certification Program, which is based on ARI Standard 810

## Ice Machine Electric

115/60/1 standard. (208-230/60/1 and 230/50/1 also available.)

**Min. circuit ampacity:** Air-cooled: 13.6 amps

Water-cooled: 12.9 amps

**Max. fuse size:** Air-cooled and Water-cooled: 20 amps

HACR-type circuit breakers can be used in place of fuses.

## Specifications

**BTU Per Hour:**

7,000 (average) 9,600 (peak)

**Compressor:**

Nominal rating: 3/4 HP

**Cupra-Nickel Condenser:**

(Water-cooled models)

Adds protection from corrosive water elements.

**Operating Limits:**

• Ambient Temperature Range:

Air and water-cooled:  
35° to 110°F (1.6° to 43.3°C)

• Water Temperature Range:  
35° to 90°F (1.6° to 32.2°C)

• Water Pressure Ice Maker  
Water In:

Min. 20 psi (137.9 kPa)  
Max. 80 psi (551.1 kPa)

• Condenser Inlet Water In:  
(Water-cooled only)

Min. 20 psi (137.9 kPa)  
Max. 150 psi (1,034.2 kPa)

## Air Flow Top View

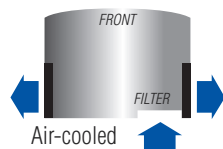

## AUCS@SO Accessory

Automatic Cleaning System purchased as an option and installed in the field.

## 2 Cube Sizes Available

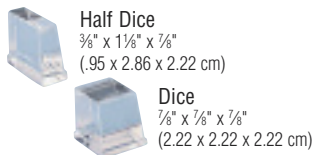

## Space-Saving Designs



	S-422 B-420	S-422 B-400*
Height	76.50" 194.31 cm	64.50" 163.93 cm
Width	22.00" 55.88 cm	30.00" 76.20 cm
Depth	34.00" 86.30 cm	34.00" 86.30 cm
Bin Storage	310 lbs. 140.7 kgs.	290 lbs. 131.7 kgs.

Height includes adjustable bin legs 6.00" to 7.00", (15.24 to 17.78 cm) set at 6.00" (15.24 cm). For comparison purposes multiply ARI capacity by 1.3 (30%) to arrive at approximate "Application Rating Capacity."  
\* K-00141 bin adapter required.

24-HOUR PRODUCTION†								lbs. kgs.	
	HALF-DICE CUBE				DICE CUBE				
	air temp	water temp			air temp	water temp			
AIR-COOLED	°F	50°	70°	90°	°F	50°	70°	90°	
	°C	10°	21°	32°	°C	10°	21°	32°	
	70°	460	420	375	70°	430	395	355	
	21°	209	191	170	21°	195	179	161	
	80°	420	380	345	80°	400	360	325	
	27°	191	172	157	27°	181	163	147	
	90°	380	355	310	90°	360	320	300	
	32°	172	161	141	32°	163	145	136	
	WATER-COOLED	70°	435	395	350	70°	430	385	345
		21°	197	179	159	21°	195	175	157
		80°	430	390	345	80°	420	380	340
		27°	195	177	157	27°	191	172	154
90°		420	370	340	90°	410	370	335	
32°		191	168	154	32°	186	168	161	

†Data is published for 60 Hz machines. 50 Hz machines produce approximately 7% less ice.

## S-422 on B-420 Storage Bin

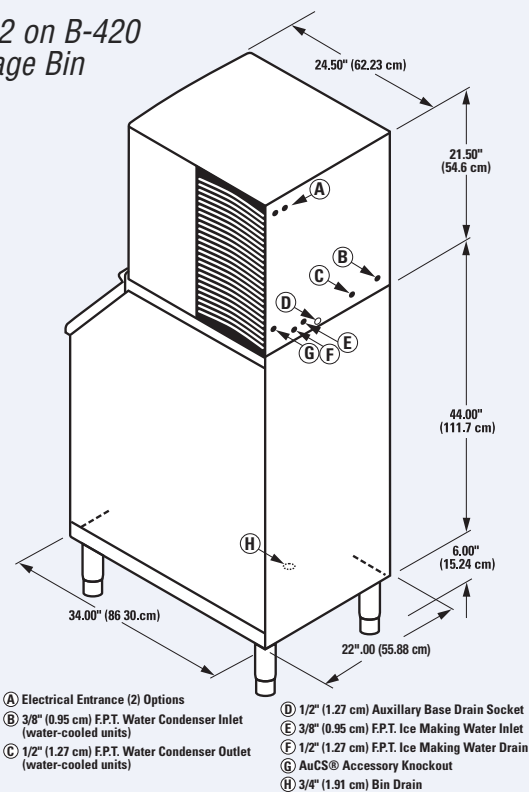

Installation Note - Minimum installation clearance— Top/sides: 8" (20.32 cm); Back: 5" (12.7 cm).



MANITOWOC ICE  
2110 South 26th Street, P.O. Box 1720  
Manitowoc, WI 54221-1720, USA  
Ph: 920-682-0161 • Fax: 920-683-7589  
Visit us online at [www.manitowocice.com](http://www.manitowocice.com)



©2008 Manitowoc. 808. Continuing product improvement may necessitate change of specifications without notice. 2979D