

Soda Factory™ Remote Refrigeration Units

2803 • 11M • 42M • 44M • 50M

 **Multiplex**

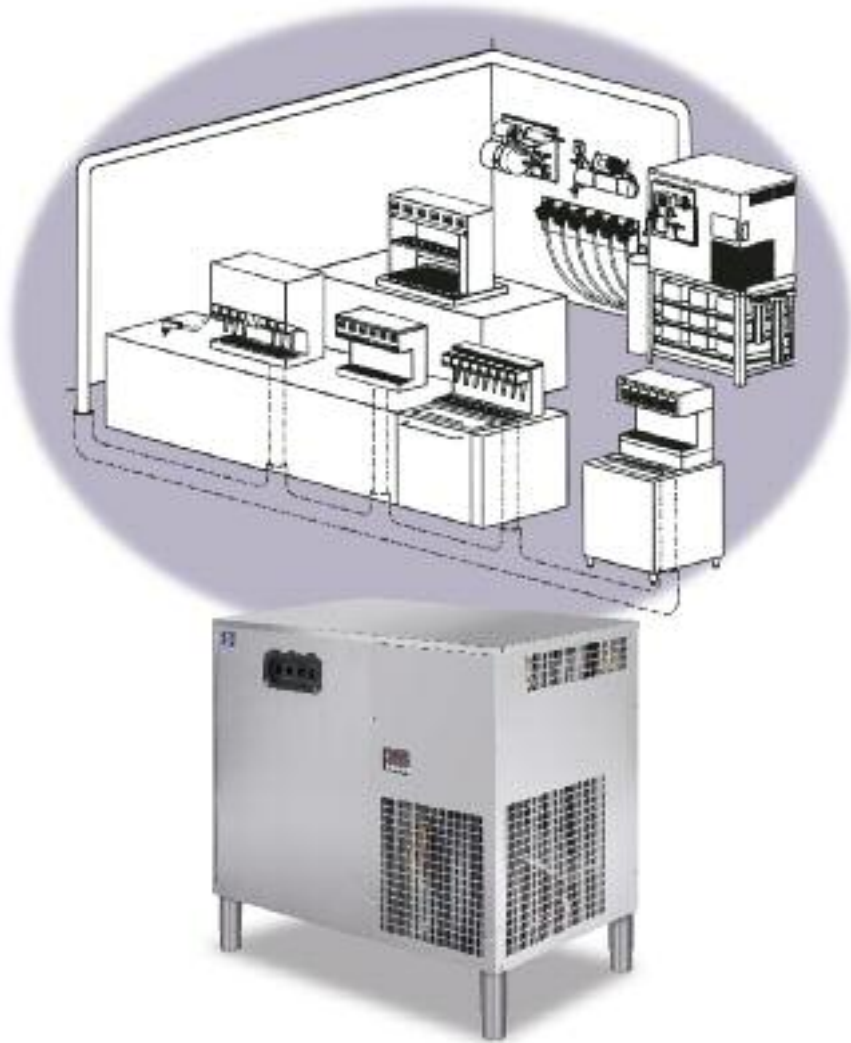

The Soda Factory™ provides the most consistent, high-quality beverages in the industry.

- Remote recirculation system keeps carbonated water and syrup chilled from location of the refrigeration unit to beverage dispensers.
- All water used for cooling drinks is recycled with virtually no waste water; reduces water and sewage expenses.
- Reduced ice consumption compared to coldplate systems.
- Durable, easy to clean stainless steel cabinet.
- Reduced counter space need compared to coldplate systems.
- Environmentally friendly R-404A refrigerant.



ISO 9001:2000
Quality System Certified

High Volume Dispensing Solutions

Remote Recirculation Soda Systems • Long Draw Beer Systems • Pre-Chillers

 **Manitowoc**

Soda Factory™ Remote Refrigeration Units 2803 • 11M • 42M • 44M • 50M

Specifications

	Model 2803	Model 11M	Model 42M	Model 44M	Model 50M
Standard Features	Internal cold carbonation, recirculation pump, stainless steel cabinet				
Electrical Requirements	120V/60Hz/1/20.3 230V/50Hz/1/9.0	120V/60Hz/1/21.5 230V/50Hz/1/10.7	208-230V/60/1/20.6 208/230V/50/1/22.0	208-230V/60Hz/3/25.5 400V/208-230V/50Hz/3/11.6	
Compressor	1/3 hp / .25 kw	1/2 hp / .37 kw	1.0 hp / .75 kw	2.2 hp / 1.6 kw	
Shipping Weights (Approximate)	130 lbs / 59 kgs	230 lbs / 104 kgs	340 lbs / 154 kgs	395 lbs / 180 kgs	
Ice Bank Size (Normal)	28 lbs / 12.7 kgs	60 lbs / 27.22 kgs	140 lbs / 63.50 kgs	200 lbs / 90.72 kgs	
Condenser (Self-contained)	Air Cooled	Air Cooled	Air or Water Cooled, or Remote		
Conduit (Maximum Run)	40 ft / 12.19m	100 ft / 30.48m	250 ft / 76.20m	350 ft / 106.70m	
Evaporator Rating (20°F / -6.5°C)	2,500 BTUH 630 kcal/hr	5,150 BTUH 1,298 kcal/hr	9,700 BTUH 2,444 kcal/hr	14,900 BTUH 3,755 kcal/hr	
Heat Rejection (Maximum)	4,500 BTUH 1,134 kcal/hr	8,638 BTUH 2,177 kcal/hr	13,576 BTUH 3,421 kcal/hr	20,400 BTUH 5,141 kcal/hr	
Carbonation System	Single tank, single 100 gph pump			Single tank dual 100 gph pumps	Dual tanks dual 100 gph pumps
Syrup Coils (Standard/Max.)	6 / 6	6 / 8	8 / 12	8 / 14	
Drink Capacity/hour*	108 / 60	228 / 150	500 / 288	600 / 420	
Options	Wall mount shelf, legs, stand, condenser filter and on the model 11 additional syrup coils and casters			Legs, stand, additional syrup coils, casters, and condenser filter	

*Peak (for 2 hrs.) / sustained (12 oz. dispensed at or below 40°F / 75°F Ambient)

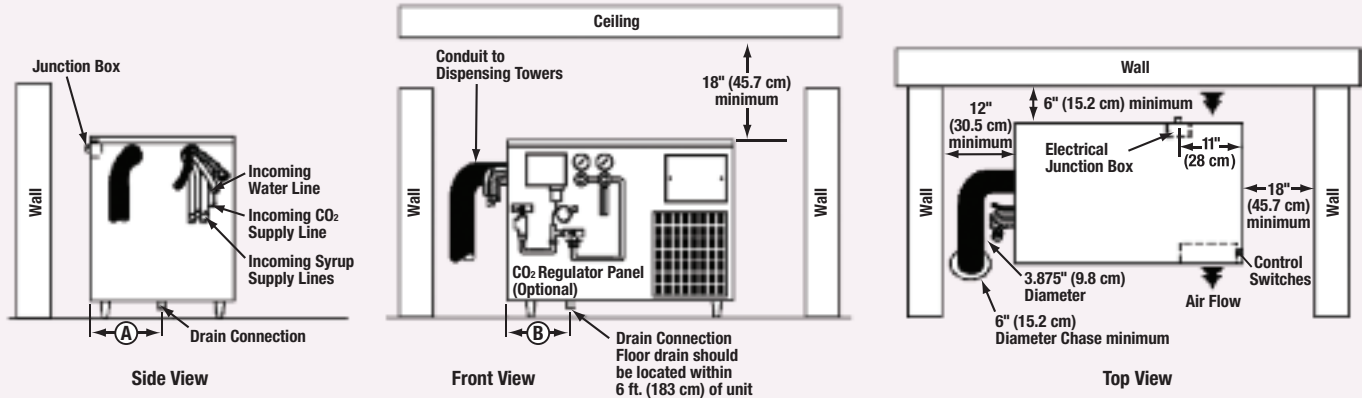

Dimensions

Unit	Width	Depth	Height	Leg Height	Drain Connection A	Drain Connection B
Model 2803	27.75" 70.5 cm	16.25" 41.3 cm	18.50" 46.9 cm	4" 10.1 cm	5.5" 14 cm	8" 20.3 cm
Model 11M	36.25" 92.07 cm	19.50" 49.5 cm	21.50" 54.6 cm	6" 15.2 cm	9" 22.9 cm	5" 12.7 cm
Model 42M	39.75" 101 cm	24.75" 62.9 cm	30.25" 76.8 cm	6" 15.2 cm	12" 30.5 cm	6" 15.2 cm
Model 44M	39.75" 101 cm	24.75" 62.9 cm	30.25" 76.8 cm	6" 15.2 cm	12" 30.5 cm	6" 15.2 cm
Model 50M	42.25" 107.3 cm	28.25" 71.8 cm	32.00" 81.3 cm	6" 15.2 cm	14" 35.6 cm	8.5" 21.6 cm

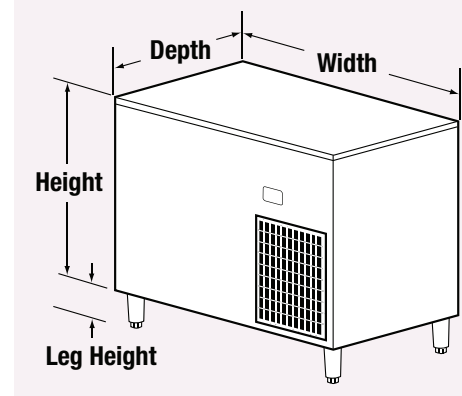

2895E ©2009 Multiplex. 9/09 Continuing product improvement may necessitate change of specifications without notice.



Multiplex

MANITOWOC BEVERAGE
2100 Future Drive
Sellersburg, IN 47172, USA
Ph: 812-246-7000 • Fax: 812-246-7024
Visit us online at www.manitowocbeverage.com

Manitowoc